



SERVICE
MANUAL **6050/6110**



marantz



model 6050/6110



Turntable



TABLE OF CONTENTS

Section	Title	Page
1.	PERFORMANCE SPECIFICATIONS	1
2.	TONE ARM ADJUSTMENTS	2
2-1.	Stylus Tracking Angle	2
2-2.	Stylus Overhang	2
2-3.	Vertical Tone Arm Balance	2
2-4.	Tracking Force	3
2-5.	Anti-Skating Adjustment	3
3.	SERVICE NOTES	4
3-1.	Voltage Conversion (European Model only)	4
3-2.	Cartridge Wire Color Code	4
3-3.	Replacement Parts / Technical Assistance	4
4.	METHOD OF PARTS ADJUSTMENT	5
4-1.	Adjustment of Tone Arm Stylus Auto Reject Position (Model 6110/6110 CT)	5
4-2.	Height Adjustment of Tone Arm in Auto Reject Mode (Model 6110/6110 CT)	5
4-3.	Motor Pulley Height Adjustment	5
4-4.	To Attach Cartridge Shell	5
4-5.	Dust Cover Replacement	5
4-6.	Motor Replacement	5
4-7.	Tone Arm Replacement	5
4-8.	Adjusting the Power ON-OFF Lever	6
5.	TROUBLESHOOTING	7
6.	DIAGRAM	8
6-1.	Schematic Diagram	8
7.	EXPLODED VIEWS / PARTS LIST	9
7-1.	[C01-99] Wood Case, Covers and General Parts	9
7-2.	[P01-99] Turntable and Motor	11
7-3.	[P02-99] Tone Arm	12
7-4.	[P03-99] Parts Assembled on the Chassis	13
7-5.	[H01-99] Packing Materials	15

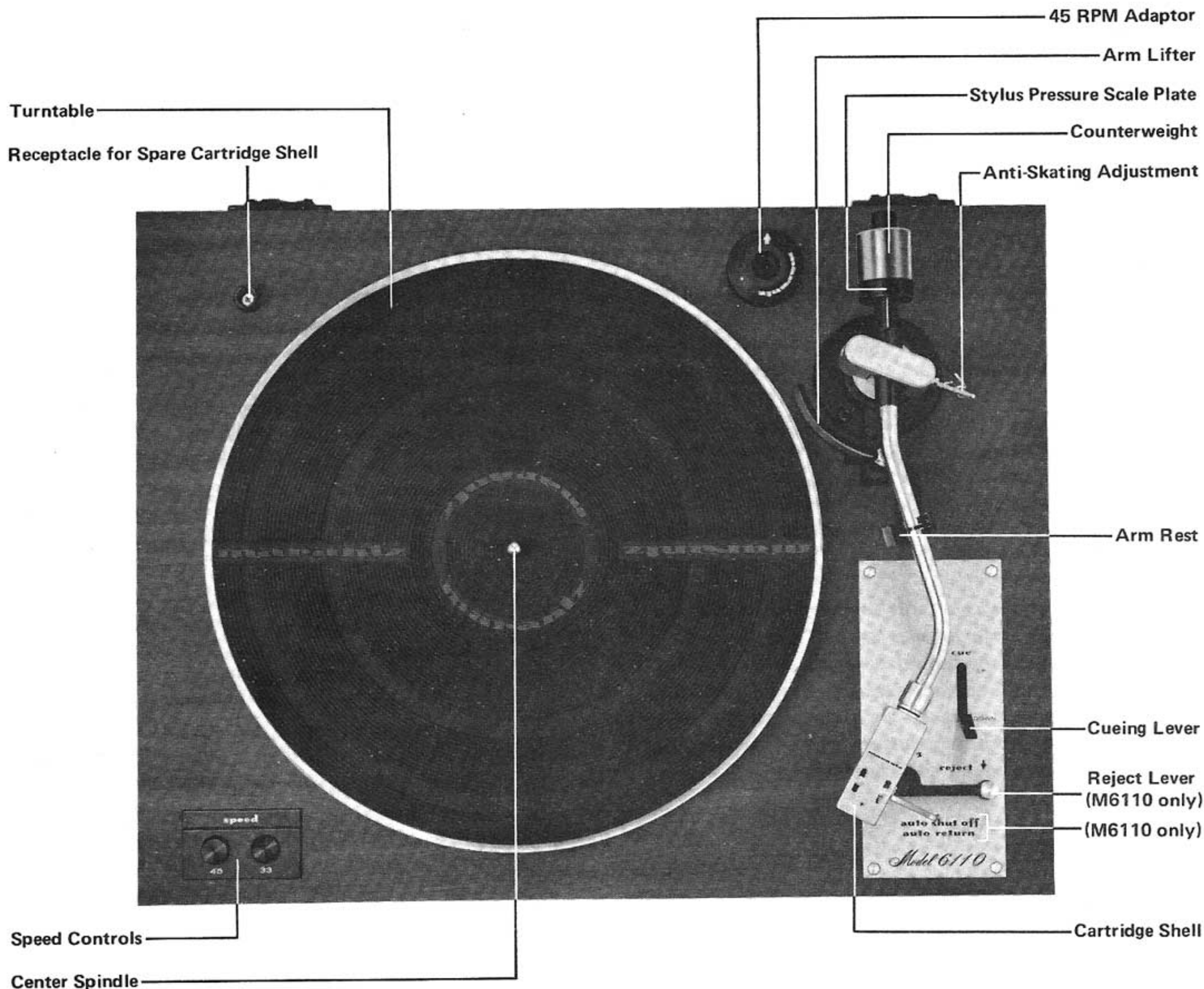

1. PERFORMANCE SPECIFICATIONS

GENERAL

Speeds:	33, 45 rpm
Speed Range:	±1.3%
Drive System:	Belt Drive
Drive Motor:	4-Pole Synchronous AC Motor
Platter Weight:	1.6 lbs. (720 g)
Platter Diameter:	11-13/16 in. (300 mm)
Rumble (DIN):	-60 dB
Wow and Flutter:	0.08%
Power Requirements:	120V AC, 60 Hz (USA and Canada Model) 110-120/220-240 V AC 50 Hz (European Model)
Power Consumption:	15 Watts
Dimensions:	17-3/4 in. x Wide x 6-1/16 in. High x 13-13/16 in. Deep (450 mm x 153 mm x 350 mm)
Weight:	13.0 lbs. (5.9 kg) Unpacked 17.4 lbs. (7.9 kg) Packed for Shipment.

TONE ARM

Length:	8-25/64 in. (215 mm)
Overhang:	15 mm
Tracking Force Adjustment Range:	0-3.0 g
Anti-Skating Force Compensation Range:	1.0-2.5 g (0.5 g Step Type)

2. TONE ARM ADJUSTMENTS

2-1. STYLUS TRACKING ANGLE

When setting up the arm for playing, it is important to check the tracking angle, because improper tracking angle will cause distortion and premature record wear. Most phono cartridges are designed so that when the cartridge is mounted on a surface parallel with the record surface, the stylus will track at the proper angle (see Figure 1). The surface inside of the cartridge shell (against which the cartridge is mounted) is parallel to the record surface when the stylus is touching the record surface. Visually check the angle of the tone arm in actual playing position. If it is not level and parallel with the record surface, then it is necessary to change the height of the tone arm by using the spacers supplied with the phono cartridge. This, of course, requires removing and remounting the cartridge, and some trial and error technique. With most cartridges, no spacers will be necessary.

NOTE: Some cartridges are built so that their bodies are at an angle with respect to their own mounting tabs. No attempt should be made to change this angle. Simply make sure that the cartridge mounting tab surfaces are parallel to the tone arm shell mounting surface before proceeding with the arm height adjustment.

2-2. STYLUS OVERHANG

Your Turntable is designed to operate with the least distortion when the tip of the stylus is at a particular distance from tone arm pivot. For this reason, the cartridge shell is slotted, allowing the cartridge with its mounting screws to be slid toward or away from the pivot point. This, in effect, changes the radius of the arc described by the stylus.

Supplied in the accessory kit is a 45 RPM spindle adaptor. The adaptor has been specially marked with an arrow and a cross to aid you in setting the proper stylus overhang. Proceed as follows:

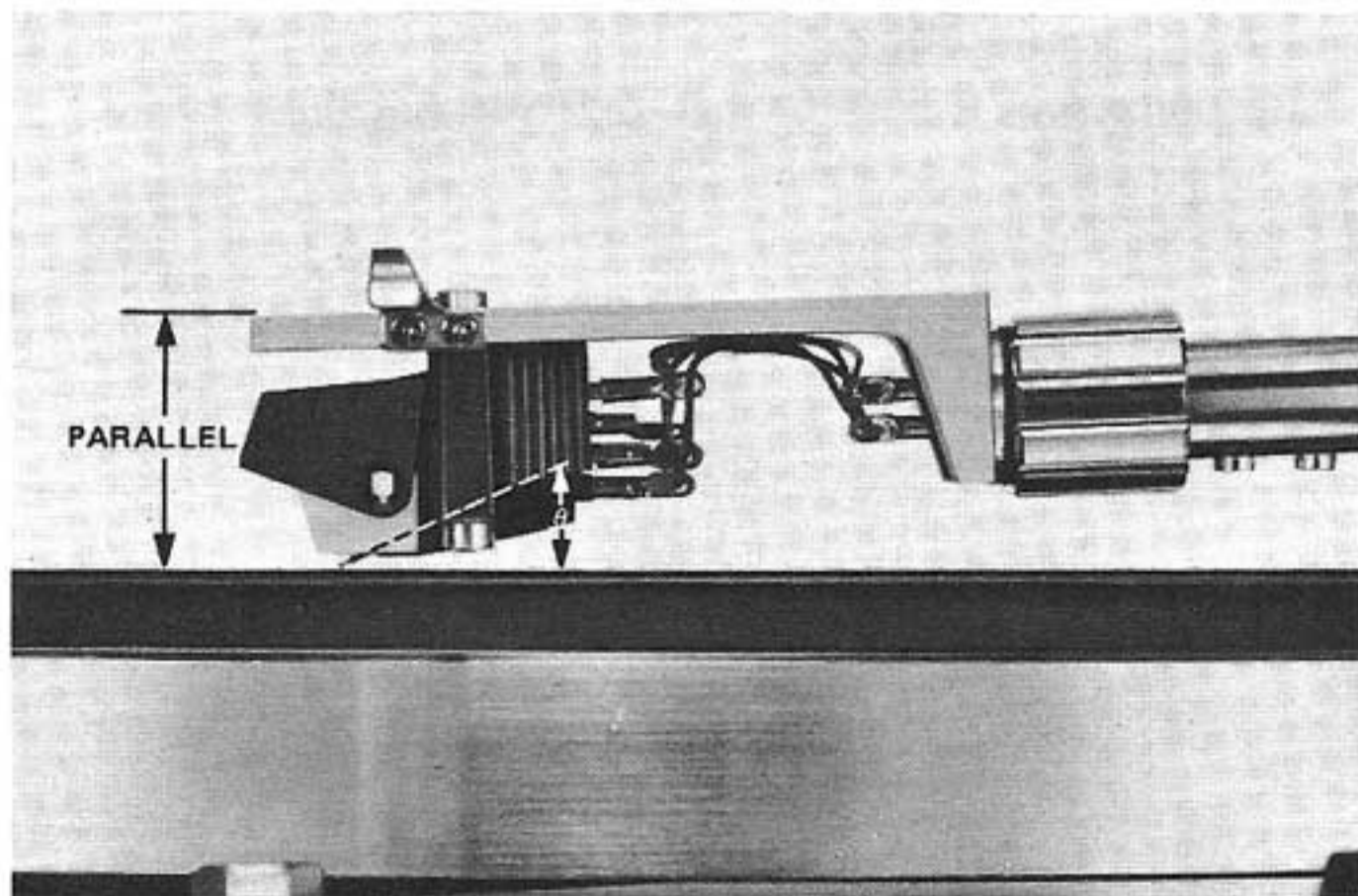

Figure 1. Tracking Angle

1. With the turntable unplugged, place the 45 RPM adaptor on the center spindle with the arrow pointing to the rear of the turntable.
2. Temporarily remove the counterweight from the tone arm.
3. Remove the arm from its arm rest and remove the protective cover (if any) from the stylus.
4. Place the stylus tip over the cross mark on the 45 RPM adaptor. It is all right for the stylus to gently touch the adaptor for checking purposes, but do not exert any downward pressure on it, or the stylus may be damaged.
5. If the stylus does not align with the cross mark, then adjustment is necessary. Place the arm in the arm rest, loosen the cartridge mounting screws, adjust, and measure again.
6. Make sure that the cartridge is installed straight; the sides of the cartridge must remain parallel to the sides of the shell.
7. When you are sure the cartridge is in the correct position, place the arm in the arm rest and snug up the mounting screws.
8. Replace the counterweight on the tone arm.

2-3. VERTICAL TONE ARM BALANCE

The adjustable counterweight at the end of the tone arm establishes tone arm balance and stylus tracking force. Since no two types of cartridges weigh the same, the balance and tracking force must be adjusted for each cartridge being used.

First, to establish a point of reference, the entire arm assembly (with cartridge installed) must be balanced. If the cartridge has a removable stylus protector, remove it, (as you would to play a record). Release the tone arm from the arm rest.



Figure 2. Stylus Overhang Adjustment

To balance the arm, adjust the position of the counterweight by rotating it. A numbered stylus pressure scale plate is located immediately in front of the counterweight. Rotating the scale plate alone does not change the counterweight's position. To change the balance, grasp and turn the counterweight itself.

Adjust the weight so that the arm is level (parallel to the turntable surface) with the cartridge suspended in mid air. Then, without moving the counterweight, set the stylus pressure scale plate to indicate zero. This establishes a reference point for setting the tracking force, which is the next adjustment.

2.4 TRACKING FORCE

For the recommended tracking force, refer to the instructions that accompany the cartridge.

Tracking force, the downward pressure of the stylus against the record, is produced by simply setting the arm off balance in the appropriate direction. That is, the counterweight is screwed inward (toward the arm pivot) until the desired downward pressure is achieved.

The stylus pressure scale plate is in frictional contact with the counterweight, so that they rotate together when the counterweight is turned. The numbers on the scale plate correspond to the tracking force measured in grams. So, if the desired tracking force is two grams, turn the counterweight inward until the stylus pressure scale plate registers 2.

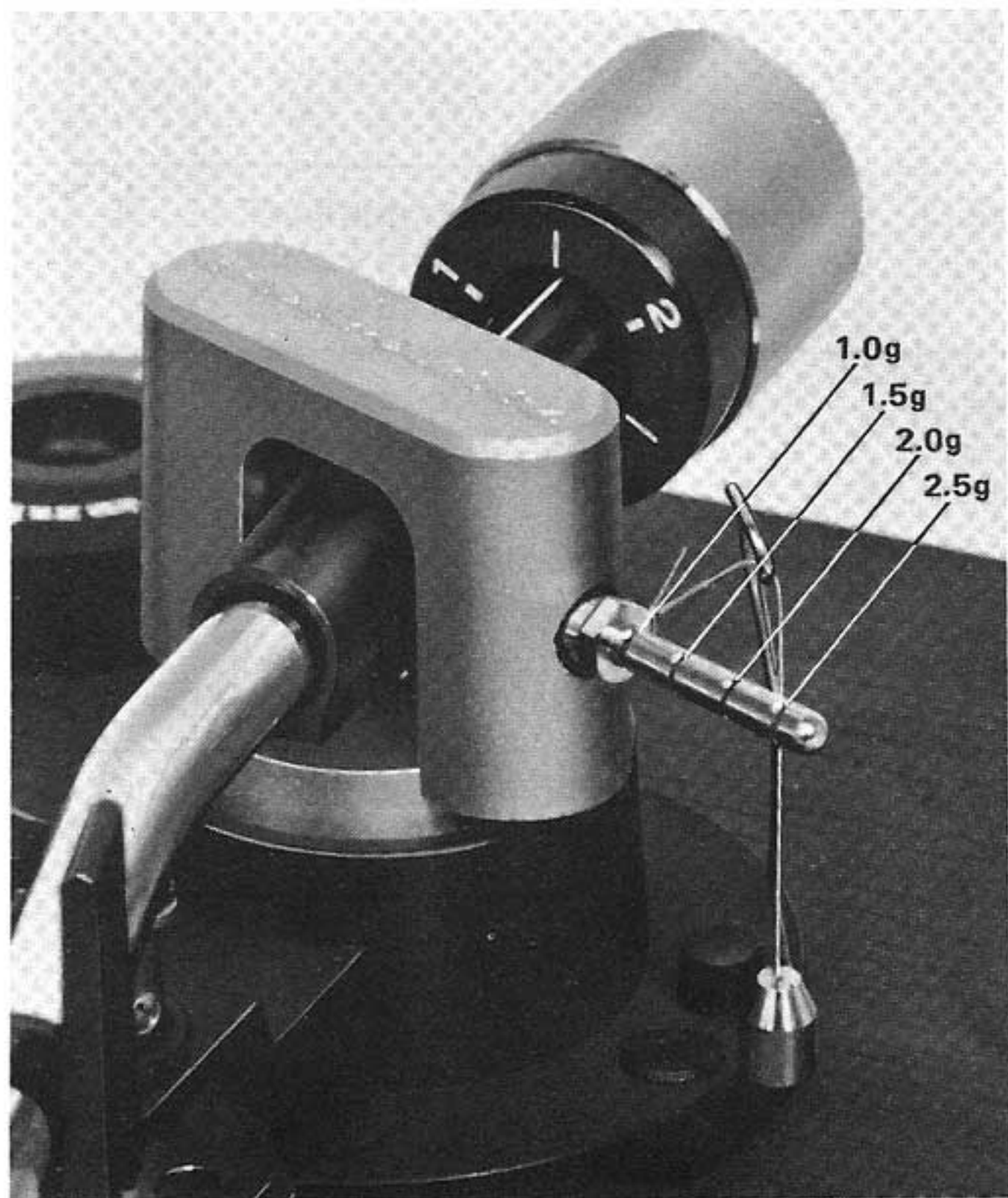

Figure 3. Anti-Skating Mechanism

2-5. ANTI-SKATING ADJUSTMENT

The anti-skating weight is provided to counteract the natural tendency of the arm to "skate" toward the center of the record as it is being played. The more tracking force used, the more anti-skating force required.

The anti-skating force can be adjusted by placing the loop in the end of the monofilament line around one of the notches in the anti-skate lever. See Figure 3 for the values these notches represent. Set the anti-skating force to the same value as the tracking force.

3. SERVICE NOTES

3-1. VOLTAGE CONVERSION (European Model only)

CAUTION: Disconnect power supply cord from AC outlet before converting voltage.

1. Remove anti-static mat from turntable platter.
2. Locate oval hole in turntable platter and remove belt from motor pulley.
3. Lift turntable platter up and remove.
4. Place the Voltage Selector Switch (S001) in the required voltage position with a screwdriver tip.
5. This version of the Model 6050 (European) is provided with a 50 Hz motor pulley mounted on the motor shaft. When the unit is being converted from 240 V to 120 V operation the 50 Hz pulley must be replaced with a 60 Hz pulley which can be obtained from the Marantz Parts Department.

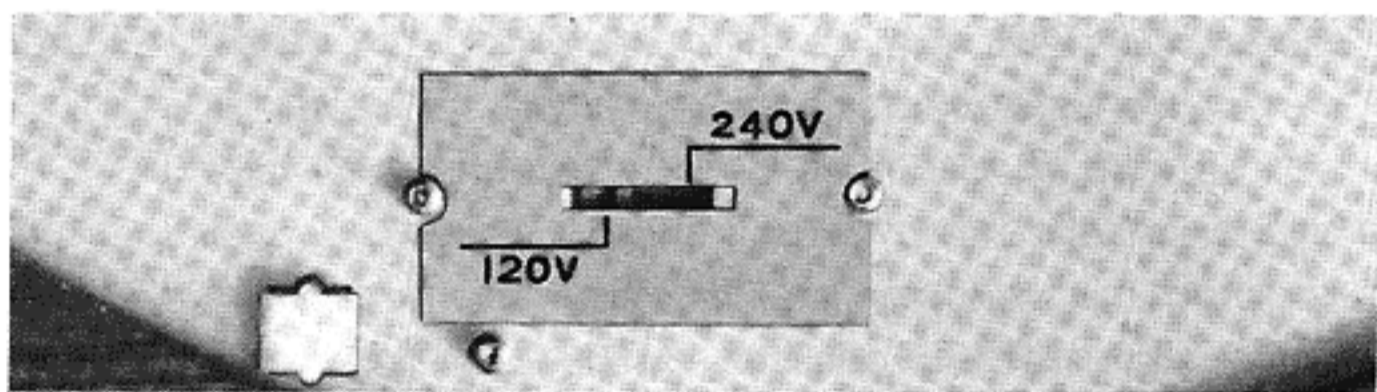

3-2. CARTRIDGE WIRE COLOR CODE

Before a cartridge is screwed into the shell, the small clips at the ends of the wires in the tone arm cartridge shell should be pushed onto their corresponding cartridge connection pins.

TONE ARM CARTRIGES SHELL — WIRE COLOR CODE —	
RIGHT CHANNEL HOT	RED
RIGHT CHANNEL GROUND	GREEN
LEFT CHANNEL HOT	WHITE
LEFT CHANNEL GROUND	BLUE

The cartridge or its accompanying technical sheet will identify the cartridge connection pins. It may be necessary to slightly compress the terminal clips with your fingers to make them fit snugly on the prongs of some cartridges.

3-3. REPLACEMENT PARTS/TECHNICAL ASSISTANCE

3-3-1. REPLACEMENT PARTS

Turntable replacement parts may be ordered by writing to;

**MARANTZ COMPANY, INC.
PARTS DEPARTMENT
P.O. BOX 577
CHATSWORTH, CALIFORNIA 91311 USA**

3-3-2. TECHNICAL ASSISTANCE

Inquiries regarding the operation and servicing of Marantz equipment should be directed to;

**MARANTZ COMPANY, INC.
TECHNICAL SERVICES DEPARTMENT
P.O. BOX 577
CHATSWORTH, CALIFORNIA 91311 USA**

4. METHOD OF PARTS ADJUSTMENT

4-1. ADJUSTMENT OF TONE ARM STYLUS AUTO REJECT POSITION (Model 6110/6110 CT)

For adjustment of the auto reject point at the end of record play proceed as follows referencing Figure 4.

1. When auto reject is delayed, turn the fine adjustment screw (065G) slightly in a counterclockwise direction. Refer to item 7-3. Chassis-Bottom View for fine adjustment screw location.
2. When auto reject occurs too soon, turn the fine adjustment screw slightly in a clockwise direction.

If proper alignment cannot be obtained with the adjustment screw because of extreme deviation of the tone arm position, proceed as follows.

1. Loosen the clamp screw (064G) holding the feed arm (066G).
2. Adjust the clearance between the feed arm (066G) and actuating arm (038G).
3. Tighten the clamp screw (064G).
4. Repeat fine adjustment procedure as in steps 1 and 2.

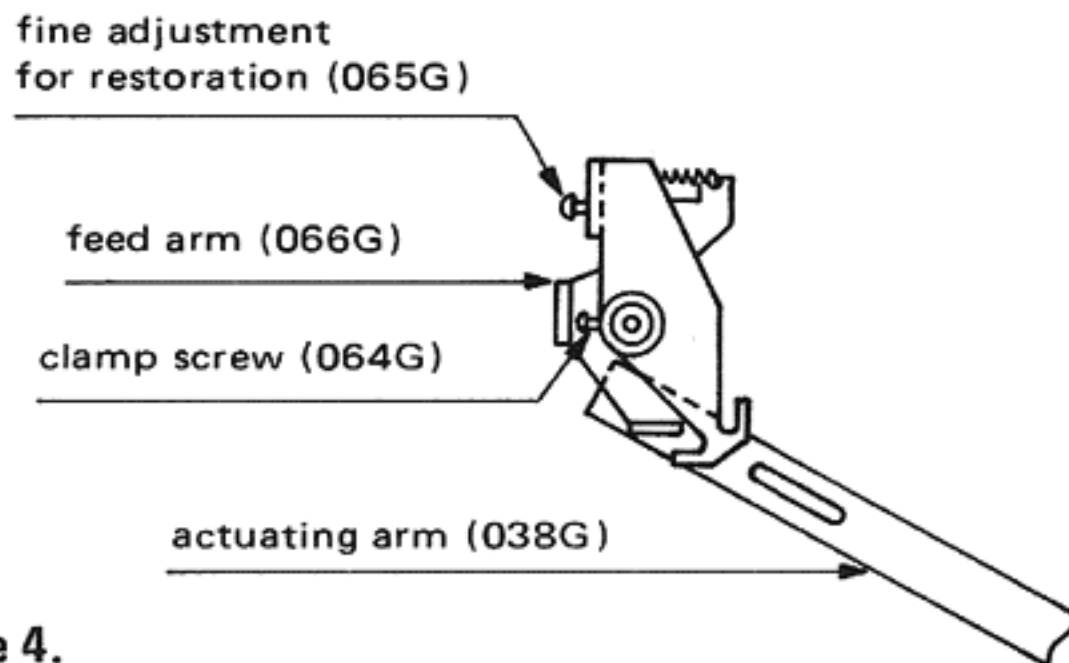

Figure 4.

4-2. HEIGHT ADJUSTMENT OF TONE ARM IN AUTO REJECT MODE (Model 6110/6110 CT)

1. Move the tone arm from the arm rest holder.
2. Put the tone arm onto the elevation stand (refer to the photograph).
3. Turn the main gear (043G) around 45 degrees counterclockwise (see the line drawing below), at which the tone arm is lifted up.
4. Adjust the screw (078G) at the end of the seesaw arm (076G) until the stylus is around 7 mm above the record disk surface, as illustrated below.
5. After seesaw arm adjustment, remove the turn table.
6. Turn the main gear (043G) and mark its lock position clearly.

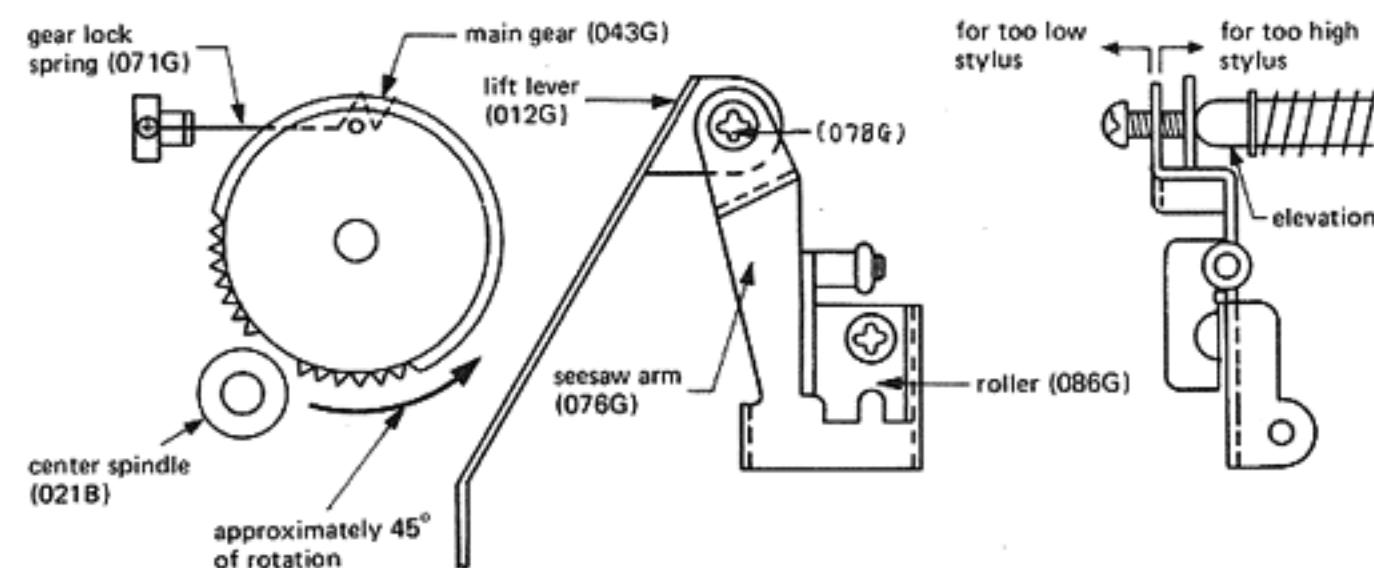

Figure 5.

4-3. MOTOR PULLEY HEIGHT ADJUSTMENT

In the event the motor pulley requires replacement make certain that the belt and the upper surface of the pulley, when the guide is positioned in the 33 R.P.M. mode, are at the same height and the belt and belt guide do not make contact.

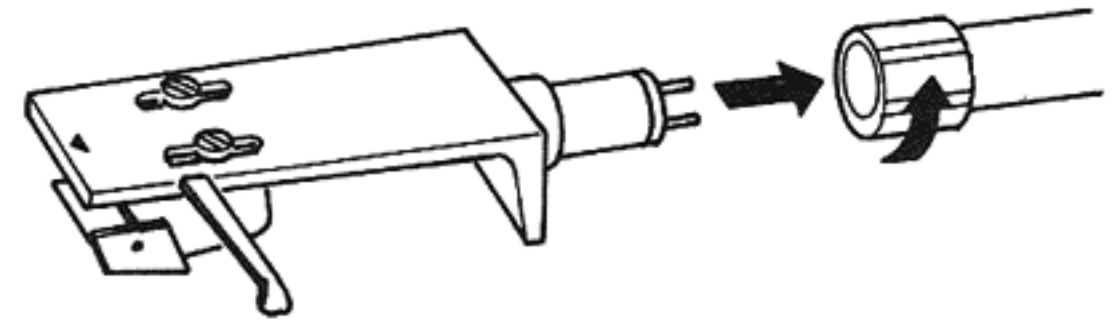

Figure 6.

4-4. TO ATTACH CARTRIDGE SHELL

Attach the cartridge shell (with cartridge) to the front end of the tone arm. As shown in Figure 6, turn the locking nut to secure the head shell in place. (For safety install the head shell with the stylus cover unremoved.)

4-5. DUST COVER REPLACEMENT

1. Lift dust cover to the open position. With unit facing forward, lift up and remove.
2. Disassembly lock plates (024D and 020D) and install on new dust cover. Attach dust cover to unit in reverse sequence of step 1.

4-6. MOTOR REPLACEMENT

1. Remove the bottom cover (010D).
2. Disconnect motor lead wires from 6-pin terminal strip (J002).
3. Remove the E clips (122G), washers (123G), and grommets (121G) from motor mounting studs and remove motor.
4. Remove motor pulley.
5. After replacement motor has been installed, make certain motor pulley is properly aligned (refer to item 4-3. for adjustment).

4-7. TONE ARM REPLACEMENT

1. Remove cartridge shell from tone arm.
2. Remove the bottom cover (010D).
3. Detach the six tone arm lead wires from 5-pin terminal strip (J001).
4. Remove the feed arm assembly (N001) from the bottom of tone arm assembly by loosening the clamp screw (064G).
5. Remove the three screws (005B) securing tone arm to wood case. Remove tone arm assembly.
6. After the new tone arm has been installed make certain that the tone arm lead wires have been properly connected to the terminal strip (J001) and all tone arm adjustments are performed.

4-8. ADJUSTING THE POWER ON-OFF LEVER

If the Tone Arm was replaced, proceed as follows. First, put the Tone Arm onto the Arm Rest. Adjust the Power ON-OFF Lever (a) until its bent end is in contact with the end of the micro switch operating bar as shown in Figure 7. Misadjustment the Lever could result in a little shift of the Tone Arm when the Lever (a) turns the micro switch off.

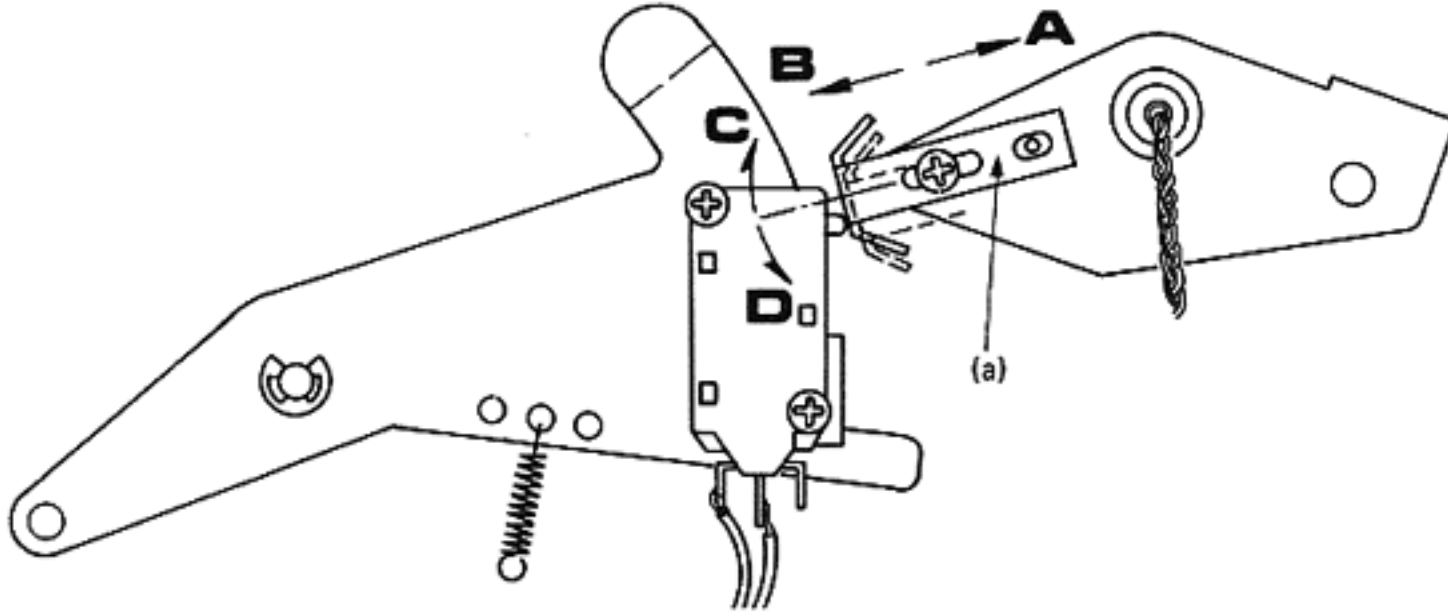

Figure 7.

5. TROUBLESHOOTING

ITEM	TROUBLE	PROBABLE CAUSE	REPAIR ACTION
1	Tone arm set in the "PLAY" position, but turntable does not rotate.	<ol style="list-style-type: none"> 1. Switch (S001) contact is bad; no current supplied to motor. 2. Broken solder connection. 3. Motor coil burned out. 	<ol style="list-style-type: none"> 1. Check switch (S001) position gap. 2. Check circuit continuity. 3. Exchange motor (M001).
2	REJECT lever is pulled to "REJECT", but tone arm does not return. (Model 6110/6110 CT)	<ol style="list-style-type: none"> 1. Actuating arm (038G) is not functioning. 2. Gear meshing is defective. 	<ol style="list-style-type: none"> 1. Check transmission mechanism related to cut-lever (031G), reject spring (108G) and REJECT lever (012B). 1. Check operational form of the clutch gear (049G, 050G). 2. Check the projection of the turntable gear (021B).
3	Upon completion of record play, tone arm does not return to rest position. (Model 6110/6110 CT)	<ol style="list-style-type: none"> 1. Switch (S001) position discrepancy. 	<ol style="list-style-type: none"> 1. Confirm switch (S001) position.
4	Tone arm returns during play. (Model 6110/6110 CT)	<ol style="list-style-type: none"> 1. Discrepancy in feed arm (006G) position (toward turntable center). 	<ol style="list-style-type: none"> 1. Adjust feed arm (066G) position.
5	Excessive noise at Auto-Return time. (Model 6110/6110 CT)	<ol style="list-style-type: none"> 1. Poor meshing between turntable gear (024B) and main gear (043G). 2. Insufficient shifting of clutch gear, or deformation of profile. 	<ol style="list-style-type: none"> 1. Inspect main gear (043G). 1. Inspect turntable gear (021B). 2. Check distance between main gear (043G) center and turntable axis (021B).
6	Tone arm stylus scratches record surface at Auto-Return time. (Model 6110/6110 CT)	<ol style="list-style-type: none"> 1. Stylus height insufficient. 	<ol style="list-style-type: none"> 1. Adjust by adjustment screw of seesaw arm (0769).
7	No electrical output from Turntable.	<ol style="list-style-type: none"> 1. Insufficient soldering of Tone arm lead wire contact. 2. Poor continuity. 3. Poor cartridge. 	<ol style="list-style-type: none"> 1. Inspect soldered contacts (N001), and (J001) on terminal strips. 2. Inspect circuitry for continuity. 3. Replace cartridge.
8	Cueing lever is "UP" but tone arm does not rise.	<ol style="list-style-type: none"> 1. Lift lever is defective. 	<ol style="list-style-type: none"> 1. Refer to item 4-2 of "Method of Parts Adjustment" section.

6. DIAGRAM

6-1. SCHEMATIC DIAGRAM

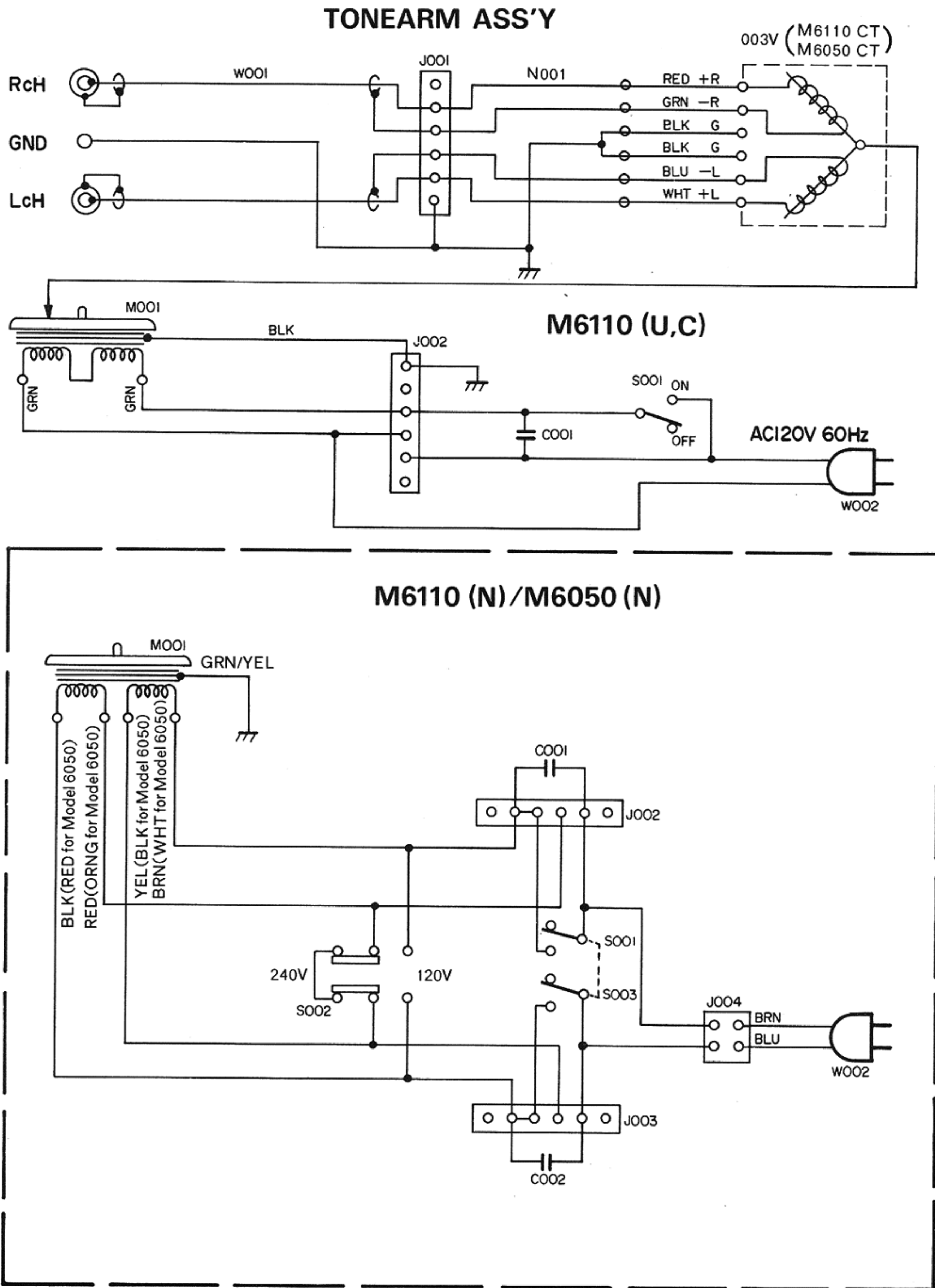

7. EXPLODED VIEWS/PARTS LIST

7-1. [C01-99] WOOD CASE, COVERS AND GENERAL PARTS

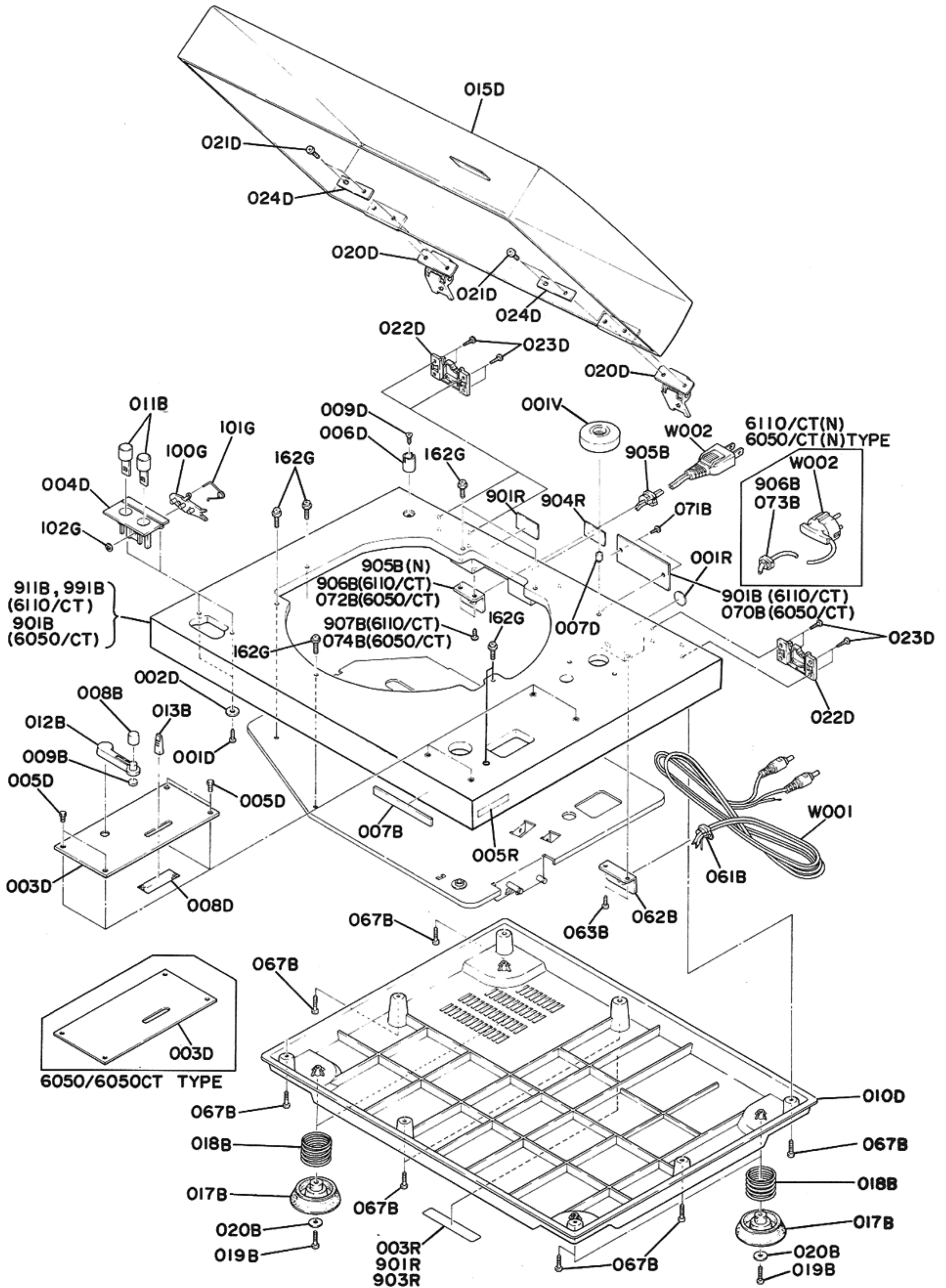

- (U) for U.S.A.
- (N) for Europe

REF. DESIG.	Q'TY		PART NO.	DESCRIPTION
	U	N		
				M6110/M6110CT (U)(N)
A	1	1	2255064400	Case Assembly
A1	1	1	2255064410	Case Assembly Silver
003D	1	1	2255063014	Escutcheon
006D	1	1	2939104020	Retainer
008D	1	1	2255303010	Mask
009D	1	1	51543113S9	F.H. Wood Screw
022D	2	2	2256160150	Bracket
023D	8	8	51522713S0	R.H. Wood Screw
071B	2	2	51770308B0	Screw
901B	1		2255265010	Indicator
901B	1		2255265033	Indicator
911B	1		2255064015	Case, Wood
911B	1		2255064024	Case, Silver
991B	1		2255064015	Case
				M6056/M6050CT (N)
A	1		2261064400	Case Assembly Brown
A1	1		2261064410	Case Assembly Silver
003D	1		2261063010	Escutcheon
006D	1		2939104020	Retainer
008D	1		2255303010	Mask
009D	1		51543113A0	F.H. Wood Screw
022D	2		2256160150	Bracket
023D	8		51522713S0	R.H. Wood Screw
070B	1		2261265010	Indicator
071B	2		51770308B0	Screw
901B	1		2255064015	Case, Brown
901B	1		2255064024	Case, Silver
				M6110/M6110CT (U)(N) M6050/M6050CT (N)
B	1	1	2224053400	Dust Cover Assembly
015D	1	1	2224053510	Cover
020D	2	2	2224153510	Hinge
021D	4	4	51100410S9	B.H.M. Screw B4 x 10
024D	2	2	2224160260	Bracket

REF. DESIG.	Q'TY		PART NO.	DESCRIPTION
	U	N		
				M6110/M6110CT (U)(N) M6050/M6050CT (N)
007B	1	1	2988251013	Badge
011B	2	2	2255154012	Knob
013B	1	1	2255154020	Knob
017B	4	4	2224057010	Leg
018B	4	4	2224115030	Spring
020B	4	4	54110149A0	Flat Washer L
061B	1	1	1455259070	Bushing
062B	1	1	2256160123	Bracket
063B	2	2	51523113A0	R.H. Wood Screw
067B	8	8	51523113A0	R.H. Wood Screw
001D	2	2	51280308B0	B.H. TAP.Screw B3 x 8
002D	2	2	54110149A0	Flat Washer L
004D	1	1	2255064032	Case (45, 33 Change Case)
005D	4	4	52014099J0	H. Head Bolt
007D	1	1	2939259020	Bushing
100G	1	1	2255354110	Lever
101G	1	1	2255115010	Spring
102G	1	1	64020300Q0	RG Ring, CS Type
162G	7	7	51260316B0	B.H. TAP. Screw B3 x 16
901R		2	3889861010	Label
904R		1	2255861040	Label
001V	1	1	2939104030	Retainer
W001	1	1	YB01000060	Connective Cord
W002		1	YC02400310	AC Power Cord
				M6110/M6110CT (U)(N)
C	1	1	2255354400	Lever Assembly
008B	1	1	2255154030	Knob
009B	1	1	2255118010	Spacer
012B	1	1	2255354010	Lever
019B	4	4	51300316B0	P.H. TAP. Screw P3 x 16
905B	1		1455259030	Bushing
905B		1	2256160170	Bracket
906B		1	1455259130	Bushing
906B	1		2256160110	Bracket
907B	2	2	51523113A0	R.H. Wood Screw
001R	1		9511101060	Label
003R	1		3889861010	Label
005R	1		2818861010	Label
903R		1	2882861020	Label
W002	1		YC01900040	A.C. Power Cord
				M6050/M6050CT (N)
019B	4		51300310B0	P.H. TAP. Screw P3 x 10
072B	1		2256160170	Bracket
073B	1		1455259130	Bushing
074B	2		51523113A0	R.H. Wood Screw

7-2. [P01-99] TURNTABLE AND MOTOR

• (U) for U.S.A.
• (N) for Europe

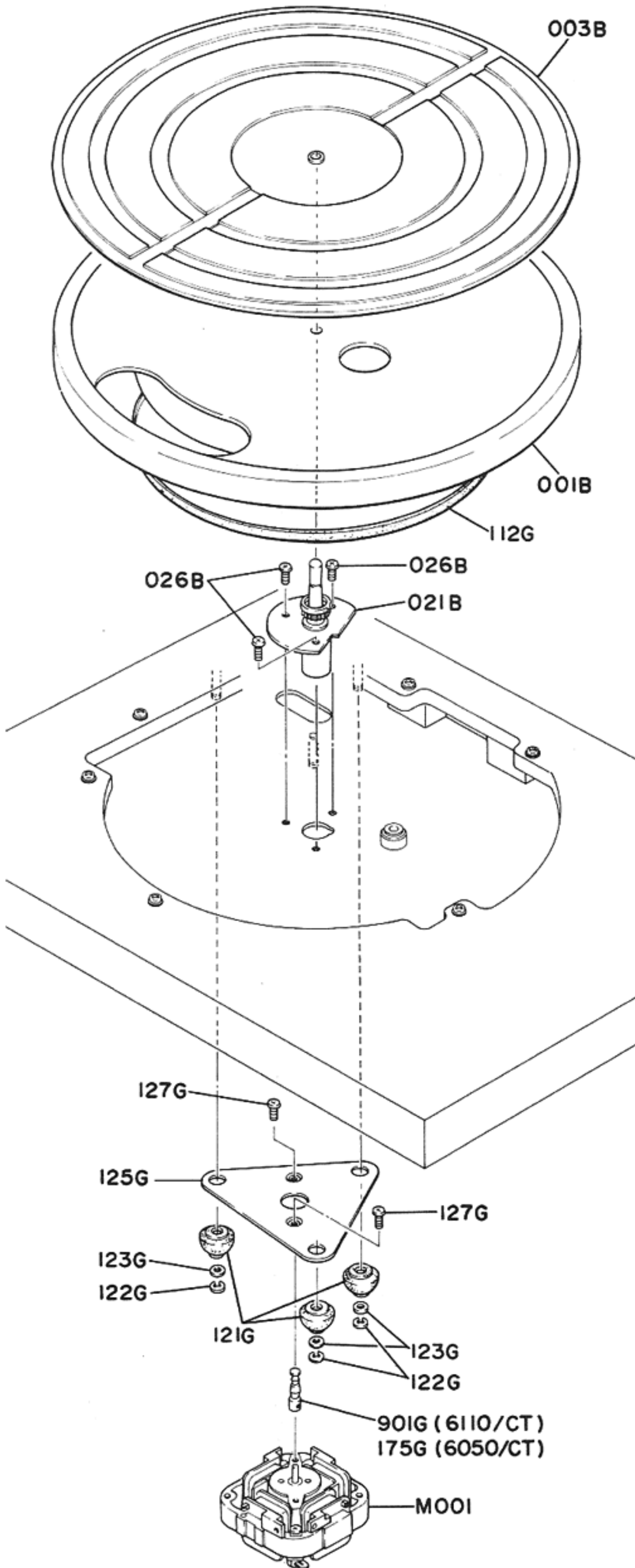

REF. DESIG.	Q'TY		PART NO.	DESCRIPTION
	U	N		
				M6110/M6110CT (U)(N) M6050/M6050CT (N)
001B	1	1	2255165010	Turn Table
003B	1	1	2255107010	Sheet
021B	1	1	2255112513	Shaft
026B	3	3	51280308B0	B.H. TAP. Screw B3 x 8
112G	1	1	2255264010	Belt
121G	3	3	2255056010	Buffer
122G	3	3	64000300R0	RG Ring. E Type
123G	3	3	59041309P0	Washer
125G	1	1	2255160020	Bracket
127G	2	2	51060308A9	P.H.M. Screw P3 x 8
901G		1	2255112110	M6110/M6110CT (U)(N) Shaft
901G	1		2255112140	Shaft
M001	1		PM12300040	Phonomotor Unit Synchronous Motor 120V
M001		1	PM12300050	Phonomotor Unit Synchronous Motor 120V/240V
175G		1	2255112110	M6050/M6050CT (N) Shaft
M001	1		PM12300050	Phonomotor Unit Synchronous Motor 120V/240V

7-3. [P02-99] TONE ARM

• (U) for U.S.A.
• (N) for Europe

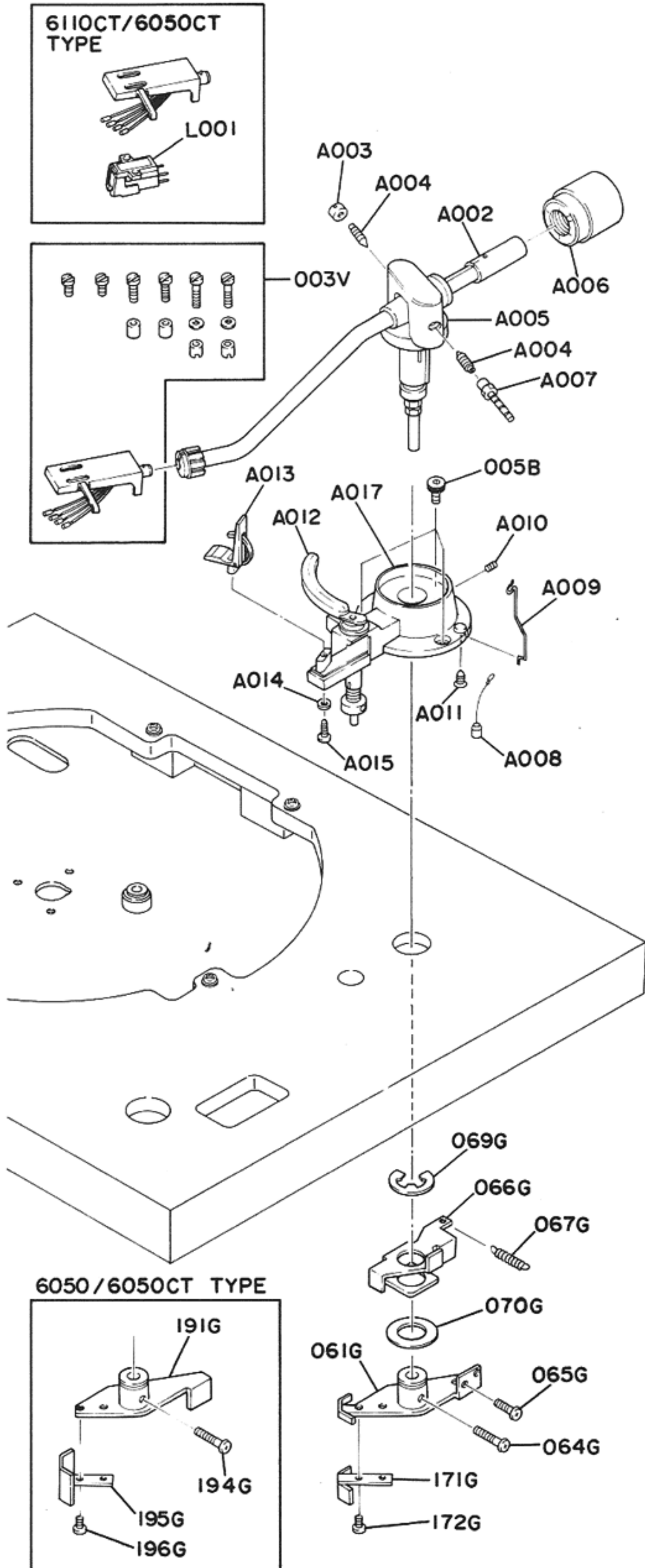

REF. DESIG.	Q'TY		PART NO.	DESCRIPTION	
	U	N			
M6110/M6110CT M6050/M6050CT					
A002	1	1	2255112160	Pipe Arm Assy	
A003	1	1	2224104210	Nut	
A004	2	2	2224104220	Screw Pivot	
A005	1	1	2255104020	Pivot Ring Assy	
A006	1	1	2224008210	Main Weight Assy	
A007	1	1	2255104030	I.F.C Bar	
A008	1	1	2255008010	I.F.C Weight	
A009	1	1	2255128010	I.F.C Stand	
A010	1	1	51650410D9	Screw	
A011	1	1	51380305P0	Screw	
A012	1	1	2255002010	Elevator Arm Assy	
A013	1	1	2224104240	Arm Rest Assy	
A014	1	1	54040202A0	Spring Washer	
A015	1	1	51380208P0	Screw	
A017	1	1	2255160100	Base Bracket Assy	
003V	1	1	YS02040070	Head Shell	
005B	3	3	52730414S9	H.S. Head Bolt	
064G	1	1	51100314A9	B.H.M. Screw	B3 x 14
M6110/M6110CT					
061G	1	1	2255354522	Lever	
065G	1	1	51062614A0	P.H.M. Screw	P2.6 x 14
066G	1	1	2255354050	Lever	
067G	1	1	2255115030	Spring	
069G	1	1	64008019R0	RG Ring, E Type	
070G	1	1	2255005010	Clamper	
171G	1	1	2255354130	Lever	
172G	1	1	51100308A9	B.H.M. Screw	B3 x 8
M6050/M6050CT (N)					
191G	1	1	2255354522	Lever	
194G	1	1	51100314A9	B.H.M. Screw	B3 x 14
195G	1	1	2255354120	Lever	
196G	1	1	51100308A0	B.H.M. Screw	B3 x 8
M6110CT/M6050CT					
L001	1	1	PC22106010	Cartridge	
	1	1	PS22106010	Stylus	

7-4. [P03-99] PARTS ASSEMBLED ON THE CHASSIS

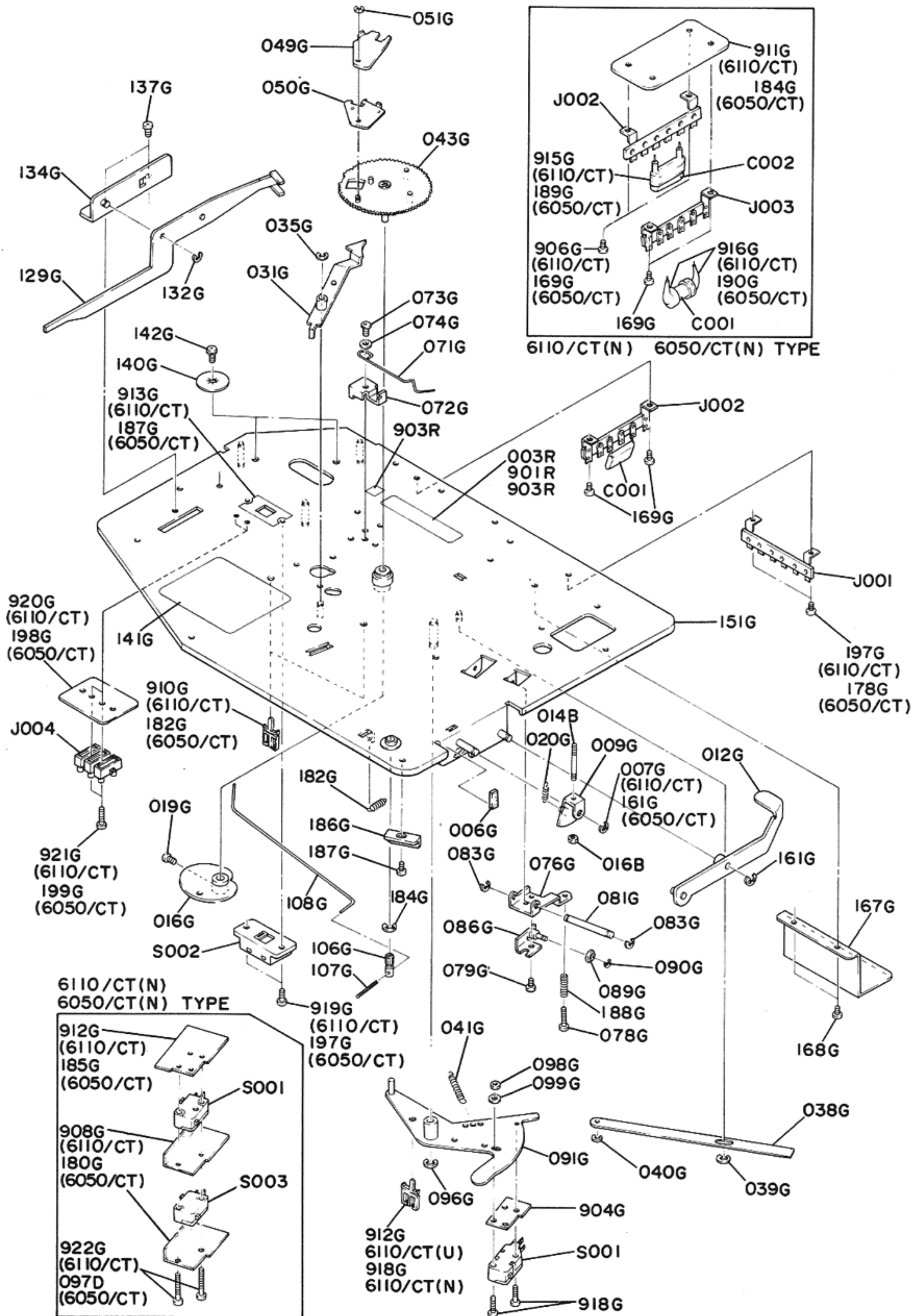

• (U) for U.S.A.
• (N) for Europe

REF. DESIG.	Q'TY		PART NO.	DESCRIPTION
	U	N		
				M6110/M6110CT (U)(N)
				M6050/M6050CT (N)
014B	1	1	2255112080	Shaft
016B	1	1	53110303A9	Hexagon Nut
009G	1	1	2255054522	Cam
012G	1	1	2255354550	Lever
020G	1	1	2255115060	Spring
129G	1	1	2255354510	Lever
132G	1	1	64000300R0	RG Ring, E Type
134G	1	1	2255160520	Bracket
137G	2	2	51280308B0	B.H. TAP. Screw B3 x 8
140G	2	2	2255861010	Label
142G	2	2	51440408Y9	L. Washer Screw P4 x 8
167G	1	1	2255109010	Shield
168G	2	2	51280306B0	B.H. TAP. Screw B3 x 6
S002	1	1	SS02020460	Voltage Selector Switch
J001	1	1	YL01060030	Terminal 6P Lug
				M6110/M6110CT (U)(N)
006G	1	1	3358118080	Spacer
007G	1	1	64000300R0	RG Ring, E Type
016G	1	1	2255054510	Cam
019G	1	1	51100310A9	B.H.M Screw B3 x 10
031G	1	1	2255354543	Lever
035G	1	1	64002500R0	RG Ring, E Type
038G	1	1	2255354080	Lever
039G	1	1	64000300R0	RG Ring, E Type
040G	1	1	64002500R0	RG Ring, E Type
041G	1	1	2255115040	Spring
043G	1	1	2255058510	Gear
049G	1	1	2255061010	Clutch
050G	1	1	2255061020	Clutch
051G	1	1	64002500R0	RG Ring, E Type
071G	1	1	2255115020	Spring
072G	1	1	2255160030	Bracket
073G	1	1	5128031480	B.H. TAP. Screw B3 x 14
074G	1	1	54020301A0	Washer
076G	1	1	2255104013	Retainer
078G	1	1	51060308A9	P.H.M Screw P3 x 8
079G	1	1	51282605B0	B.H.M Screw B2.6 x 5
081G	1	1	2255112150	Shaft
083G	2	2	64002500R0	RG Ring, E Type
086G	1	1	2255160530	Bracket
089G	1	1	2255358010	Roller
090G	1	1	64000200R0	RG Ring, E Type
091G	1	1	2255354530	Lever
096G	1	1	64000400R0	RG Ring, E Type
098G	1	1	53110303B9	Hexagon Nut
099G	1	1	54020301A0	Flat Washer P
106G	1	1	2255112040	Shaft
107G	1	1	2255254070	Pin
108G	1	1	2255125013	Joint
141G	1	1	2255861020	Label
151G	1	1	2255105515	Chassis
161G	1	1	64000300R0	RG Ring, E Type
169G	2	2	51280306B0	B.H. TAP. Screw B3 x 6
182G	1	1	4367115280	Spring
184G	1	1	64000400R0	RG Ring, E Type
186G	1	1	2255114023	Stopper
187G	1	1	51280306N0	B.H. TAP. Screw B3 x 6

REF. DESIG.	Q'TY		PART NO.	DESCRIPTION
	U	N		
188G	1	1	4380115090	Spring
197G	2	2	51280308B0	B.H. TAP. Screw B3 x 8
904G	1		2255120022	Insulator
906G		2	51280306B0	B.H. TAP. Screw B3 x 6
908G		2	2256120060	Insulator
910G	2	2	2886005040	Clamper
911G		1	2255120010	Insulator
912G		1	2255120022	Insulator
912G	1		2886005040	Clamper
913G		1	2255861030	Label
915G		1	2255120030	Insulator
916G		2	2970120030	Insulator
918G	2		51100316A9	B.H.M. Screw B3 x 16
918G		1	2886005040	Clamper
919G	2	2	51280308B0	B.H. TAP. Screw B3 x 8
920G	1	1	4113120010	Insulator
921G	2	2	51280316B0	B.H. TAP. Screw B3 x 16
922G		2	50060330B9	B.H.M. Screw B3 x 30
003R	1		3889861010	Label
901R		1	3889861010	Label
903R		1	2882861020	Label
S001		1	SM01020090	Micro Power Switch
S001	1		SM01020150	Micro Power Switch
S003		1	SM01020090	Micro Power Switch
C001	1		DF17473600	Film Cap 0.047 μ F \pm 20%
C001		1	DO07473540	Oil Paper Cap 0.47 μ F \pm 20%
C002		1	DF17473580	Film Cap 0.47 μ F \pm 20%
J002	1		YL01060030	Terminal 6P Lug
J002		1	YL01060080	Terminal 6P Lug
J003		1	YL01060080	Terminal 6P Lug
				M6050/M6050CT (N)
097D		2	50060330B9	B.H.M. Screw B3 x 30
151G		1	2261105512	Chassis
161G		2	64000300R0	RG Ring, E Type
169G		2	51280306B0	B.H. TAP. Screw B3 x 6
178G		2	51280306B0	B.H. TAP. Screw B3 x 6
180G		2	2224120010	Insulator
182G		2	2886005030	Clamper
184G		1	2255120010	Insulator
185G		1	2255120022	Insulator
187G		1	2255861030	Label
189G		1	2255120030	Insulator
190G		2	2970120030	Insulator
197G		2	51280308B0	B.H. TAP. Screw B3 x 8
198G		1	4113120010	Insulator
199G		2	51280316B0	B.H. TAP. Screw B3 x 16
901R		1	3889861010	Label
903R		1	2882861020	Label
S001		1	SM01020090	Micro Power Switch
S003		1	SM01020090	Micro Power Switch
C001		1	DO07473540	Oil Paper Cap 0.47 μ F \pm 20%
C002		1	DF17473580	Film Cap 0.47 μ F \pm 20%
J002		1	YL01060080	Terminal 6P Lug
J003		1	YL01060080	Terminal 6P Lug

8-5. [H01-99] PACKING MATERIALS

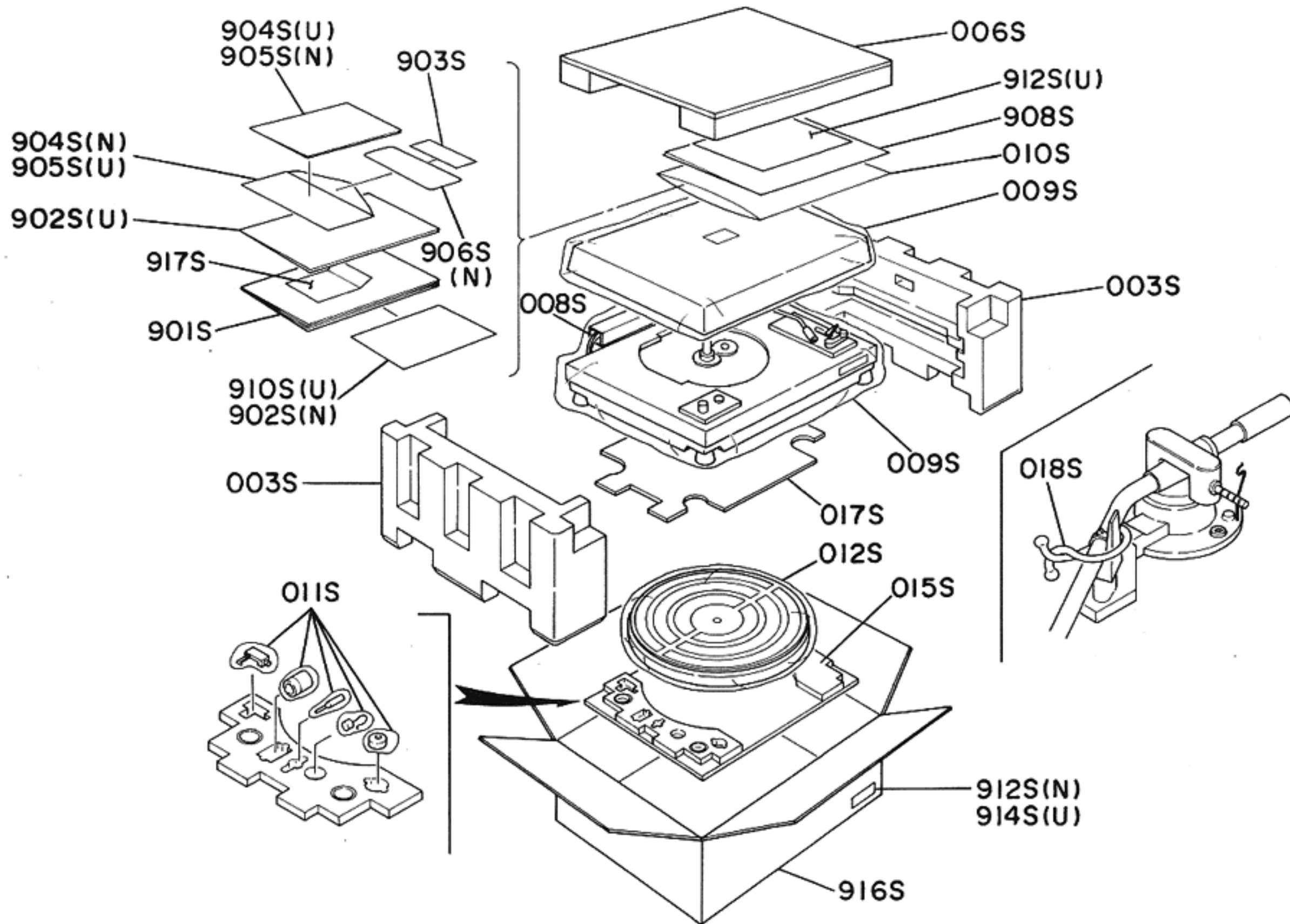

• (U) for U.S.A.
• (N) for Europe

REF. DESIG.	Q'TY		PART NO.	DESCRIPTION
	U	N		
				M6110/M6110CT (U)(N)
				M6050/M6050CT (N)
003S	2	2	2255803012	Partitioner
006S	1	1	2255807022	Reinforcing
008S	2	2	2864804010	Sleeve
009S	2	2	9014543380	Polyethy Bag
010S	1	1	9013025010	Polyethy Bag
011S	5	5	9010510010	Polyethy Bag
012S	1	1	9013540010	Polyethy Bag
015S	1	1	2255803510	Partitioner
017S	1	1	2255803030	Partitioner
018S	1	1	2256005050	Clamper
				M6110/M6110CT
901S	1		2255851010	Instructions
901S		1	2255851310	Instructions
902S		1	2255851030	Instructions
902S	1		2818854020	Guarantee Card
903S		1	2255851070	Instructions
903S	1		2577854010	Guarantee Card
904S	1		2577851020	Instructions
904S		1	2818813010	Envelope
905S	1		2577813010	Envelope
905S		1	2818851120	Instructions

REF. DESIG.	Q'TY		PART NO.	DESCRIPTION
	U	N		
906S		1	9630000180	Guarantee Card
908S	1		2255851060	Instructions
908S		1	2818851140	Instructions
910S	1		2255851020	Instructions
910S		1	9560000043	Hang Tag
912S	1		2818851040	Instructions
912S		3	9523015130	Serial No. Card
914S	3		9522815010	Serial No. Card
916S	1	1	2255801010	Packing Case
917S	1		2225813010	Envelope
				M6050/M6050CT
901S		1	2261851310	Instructions
902S		1	2255851030	Instructions
903S		1	2255851070	Instructions
904S		1	2818813010	Envelope
905S		1	2818851120	Instructions
906S		1	9630000180	Guarantee Card
908S		1	2818851140	Instructions
910S		1	9560000043	Hang Tag
912S		3	9523015130	Serial No. Card
916S		1	2261801010	Packing Case

(W01-99)	Assembly and Wiring
(T01-99)	Adjustment
(X01-00)	Correction



marantz.

MARANTZ CO., INC. • P.O. BOX 577 • CHATSWORTH, CALIFORNIA • 91311



A WHOLLY-OWNED SUBSIDIARY OF SUPERSCOPE INC., CHATSWORTH, CALIFORNIA • 91311